

CD4503BM/CD4503BC Hex Non-Inverting TRI-STATE® Buffer

General Description

The CD4503B is a hex non-inverting TRI-STATE buffer with high output current sink and source capability. TRI-STATE outputs make it useful in bus-oriented applications. Two separate disable inputs are provided. Buffers 1 through 4 are controlled by the disable 4 input. Buffers 5 and 6 are controlled by the disable 2 input. A high level on either disable input will cause those gates on its control line to go into a high impedance state.

Features

- Wide supply voltage range 3.0 V_{DC} to 18 V_{DC}
- TRI-STATE outputs
- Symmetrical turn on/turn off delays
- Symmetrical output rise and fall times
- Pin-for-pin replacement for MM80C97 and MC14503

Schematic and Connection Diagrams

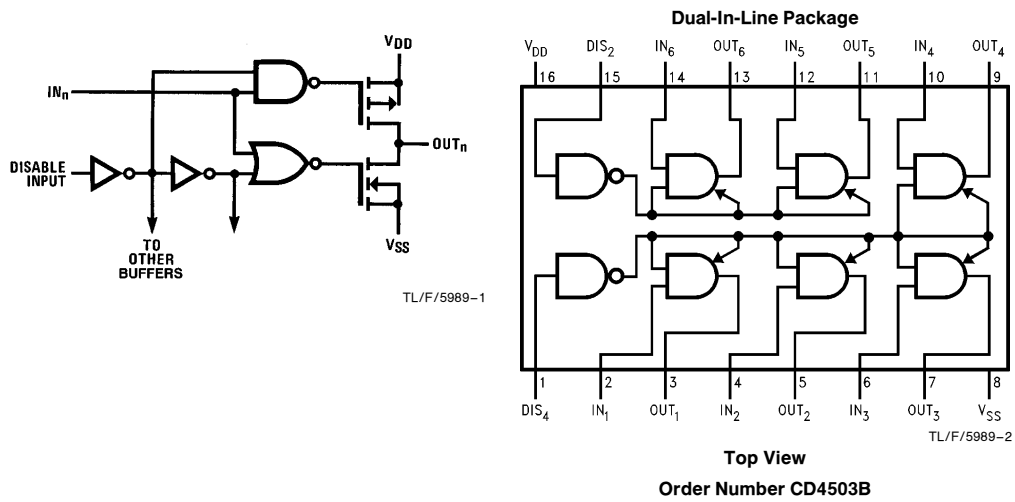

Truth Table

In	Disable Input	Out
0	0	0
1	0	1
X	1	TRI-STATE

X = Don't Care

TRI-STATE® is a registered trademark of National Semiconductor Corporation.

Absolute Maximum Ratings (Notes 1 and 2)

If Military/Aerospace specified devices are required, please contact the National Semiconductor Sales Office/Distributors for availability and specifications.

Supply Voltage (V_{DD})	–0.5V to +18V
Input Voltage (V_{IN})	–0.5V to +0.5V
Storage Temperature Range (T_S)	–65°C to +150°C
Power Dissipation (P_D)	
Dual-In-Line	700 mW
Small Outline	500 mW
Lead Temperature (T_L)	
(Soldering, 10 seconds)	260°C

Recommended Operating Conditions (Note 2)

Supply Voltage (V_{DD})	+3V to +15V
Operating Temperature Range (T_A)	
CD4503BM	–55°C to +125°C
CD4503BC	–40°C to +85°C

DC Electrical Characteristics CD4503BM (Note 2)

Symbol	Parameter	Conditions	–55°C		+25°			+125°C		Units
			Min	Max	Min	Typ	Max	Min	Max	
I_{DD}	Quiescent Device Current	$V_{DD} = 5V,$ $V_{IN} = V_{DD}$ or V_{SS}		1			1		30	μA
		$V_{DD} = 10V,$ $V_{IN} = V_{DD}$ or V_{SS}		2			2		60	μA
		$V_{DD} = 15V,$ $V_{IN} = V_{DD}$ or V_{SS}		4			4		120	μA
V_{OL}	Low Level Output Voltage	$V_{IN} = V_{DD}$ or 0								
		$V_{DD} = 5V$		0.05		0	0.05		0.05	V
		$V_{DD} = 10V$ $V_{DD} = 15V$		0.05		0	0.05		0.05	V
V_{OH}	High Level Output Voltage	$V_{IN} = V_{DD}$ or 0								
		$V_{DD} = 5V$	4.95		4.95	5		4.95		V
		$V_{DD} = 10V$ $V_{DD} = 15V$	9.95 14.95		9.95 14.95	10 15		9.95 14.95		V
V_{IL}	Low Level Input Voltage	$V_{DD} = 5V,$ $V_O = 4.5V$ or $0.5V$		1.5		2.25	1.5		1.5	V
		$V_{DD} = 10V,$ $V_O = 9.0V$ or $1.0V$		3.0		4.50	3.0		3.0	V
		$V_{DD} = 15V,$ $V_O = 13.5V$ or $1.5V$		4.0		6.75	4.0		4.0	V
V_{IH}	High Level Input Voltage	$V_{DD} = 5V,$ $V_O = 0.5V$ or $4.5V$	3.5		3.5	2.75		3.5		V
		$V_{DD} = 10V,$ $V_O = 1.0V$ or $9.0V$	7.0		7.0	5.5		7.0		V
		$V_{DD} = 15V,$ $V_O = 1.5V$ or $13.5V$	11.0		11.0	8.25		11.0		V
I_{OL}	Low Level Output Current (Note 3)	$V_{DD} = 4.5V, V_{OL} = 0.4V$	2.80		2.30	2.55		1.60		mA
		$V_{DD} = 5.0V, V_{OL} = 0.4V$	3.00		2.40	2.75		1.75		mA
		$V_{DD} = 10V, V_{OL} = 0.5V$	7.85		6.35	7.00		4.45		mA
		$V_{DD} = 15V, V_{OL} = 1.5V$	19.95		16.10	25.00		11.30		mA
I_{OH}	High Level Output Current (Note 3)	$V_{DD} = 5V, V_{OH} = 4.6V$	–1.28		–1.02	–1.76		–0.72		mA
		$V_{DD} = 10V, V_{OH} = 9.5V$	–3.20		–2.60	–4.5		–1.8		mA
		$V_{DD} = 15V, V_{OH} = 13.5V$	–8.20		–6.80	–17.6		–4.8		mA
I_{OZ}	TRI-STATE Leakage Current	$V_{DD} = 15V$		± 0.1		$\pm 10^{-4}$	± 0.1		± 1.0	μA
I_{IN}	Input Current	$V_{DD} = 15V$		± 0.1		$\pm 10^{-4}$	± 0.1		± 1.0	μA

Note 1: "Absolute Maximum Ratings" are those values beyond which the safety of the device cannot be guaranteed. They are not meant to imply that the devices should be operated at these limits. The tables of "Recommended Operating Conditions" and "Electrical Characteristics" provide conditions for actual device operation.

Note 2: $V_{SS} = 0V$ unless otherwise specified.

Note 3: I_{OH} and I_{OL} are tested one output at a time.

DC Electrical Characteristics CD4503BC (Note 2)

Symbol	Parameter	Conditions	-40°C		+25°C			+85°C		Units
			Min	Max	Min	Typ	Max	Min	Max	
I _{DD}	Quiescent Device Current	V _{DD} = 5V, V _{IN} = V _{DD} or V _{SS}		4			4		30	μA
		V _{DD} = 10V, V _{IN} = V _{DD} or V _{SS}		8		8		60	μA	
		V _{DD} = 15V, V _{IN} = V _{DD} or V _{SS}		16		16		120	μA	
V _{OL}	Low Level Output Voltage	V _{IN} = V _{DD} or 0								
		V _{DD} = 5V		0.05		0	0.05		0.05	V
		V _{DD} = 10V		0.05		0	0.05		0.05	V
		V _{DD} = 15V		0.05		0	0.05		0.05	V
V _{OH}	High Level Output Voltage	V _{IN} = V _{DD} or 0								
		V _{DD} = 5V	4.95		4.95			4.95		V
		V _{DD} = 10V	9.95		9.95			9.95		V
		V _{DD} = 15V	14.95		14.95			14.95		V
V _{IL}	Low Level Input Voltage	V _{DD} = 5V, V _O = 4.5V or 0.5V		1.5		2.25	1.5		1.5	V
		V _{DD} = 10V, V _O = 9.0V or 1.0V		3.0		4.50	3.0		3.0	V
		V _{DD} = 15V, V _O = 13.5V or 1.5V		4.0		6.75	4.0		4.0	V
V _{IH}	High Level Input Voltage	V _{DD} = 5V, V _O = 0.5V or 4.5V	3.5		3.5	2.75		3.5		V
		V _{DD} = 10V, V _O = 1.0V or 9.0V	7.0		7.0	5.5		7.0		V
		V _{DD} = 15V, V _O = 1.5V or 13.5V	11.0		11.0	8.25		11.0		V
I _{OL}	Low Level Output Current (Note 3)	V _{DD} = 4.5V, V _{OL} = 0.4V	2.30		1.95	2.65		1.60		mA
		V _{DD} = 5.0V, V _{OL} = 0.4V	2.5		2.10	2.75		1.75		mA
		V _{DD} = 10V, V _{OL} = 0.5V	6.5		5.45	7.0		4.45		mA
		V _{DD} = 15V, V _{OL} = 1.5V	16.50		13.80	25.00		11.30		mA
I _{OH}	High Level Output Current (Note 3)	V _{DD} = 5V, V _{OH} = 4.6V	-1.04		-0.88	-1.76		-0.7		mA
		V _{DD} = 10V, V _{OH} = 9.5V	-2.60		-2.2	-4.50		-1.8		mA
		V _{DD} = 15V, V _{OH} = 13.5V	-7.2		-6.0	-17.6		-4.8		mA
I _{TL}	TRI-STATE Leakage Current	V _{DD} = 15V		±0.3		±10 ⁻⁴	±0.3		±1.0	μA
I _{IN}	Input Current	V _{DD} = 15V		±0.3		±10 ⁻⁵	±0.3		±1.0	μA

Note 1: "Absolute Maximum Ratings" are those values beyond which the safety of the device cannot be guaranteed. They are not meant to imply that the devices should be operated at these limits. The tables of "Recommended Operating Conditions" and "Electrical Characteristics" provide conditions for actual device operation.

Note 2: V_{SS} = 0V unless otherwise specified.

AC Electrical Characteristics* CD4503B

$T_A = 25^\circ\text{C}$, $C_L = 50\text{ pF}$, $R_L = 200\text{ k}\Omega$, Input $t_r = t_f = 20\text{ ns}$, unless otherwise specified

Symbol	Parameter	Conditions	Min	Typ	Max	Units
t_{PHL} , t_{PLH}	Propagation Delay Time	$V_{DD} = 5\text{V}$ $V_{DD} = 10\text{V}$ $V_{DD} = 15\text{V}$		75 35 25	100 40 30	ns
t_{PLZ} , t_{PHZ}	Propagation Delay Time, Logical Level to High Impedance State	$V_{DD} = 5\text{V}$ $V_{DD} = 10\text{V}$ $V_{DD} = 15\text{V}$		80 40 35	125 90 70	ns
t_{PZL} , t_{PZH}	Propagation Delay Time, High Impedance State to Logical Level	$V_{DD} = 5\text{V}$ $V_{DD} = 10\text{V}$ $V_{DD} = 15\text{V}$		95 40 35	175 80 70	ns
t_{TLH}	Output Rise Time	$V_{DD} = 5\text{V}$ $V_{DD} = 10\text{V}$ $V_{DD} = 15\text{V}$		45 23 18	80 40 35	ns
t_{THL}	Output Fall Time	$V_{DD} = 5\text{V}$ $V_{DD} = 10\text{V}$ $V_{DD} = 15\text{V}$		45 23 18	80 40 35	ns

*AC Parameters are guaranteed by DC correlated testing.

AC Test Circuits and Switching Time Waveforms

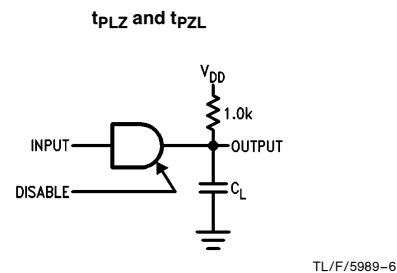
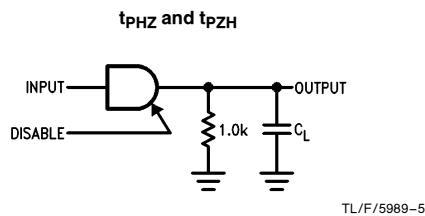
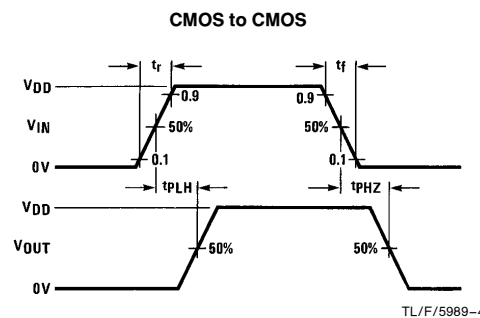
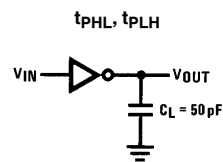

AC Test Circuits and Switching Time Waveforms (Continued)

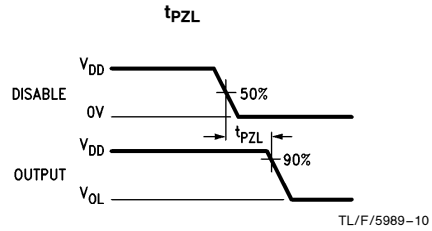
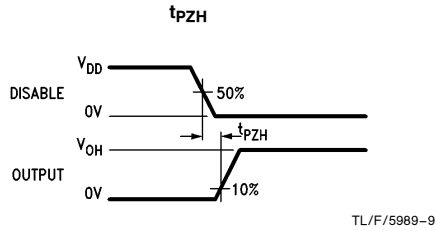
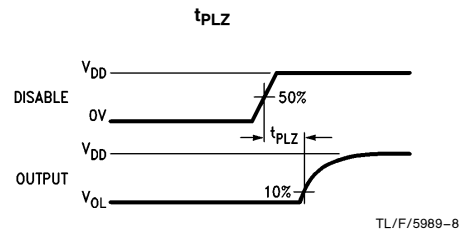
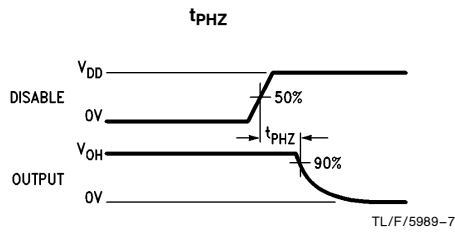

Note: Delays measured with input $t_r, t_f \leq 20$ ns.

Physical Dimensions inches (millimeters)

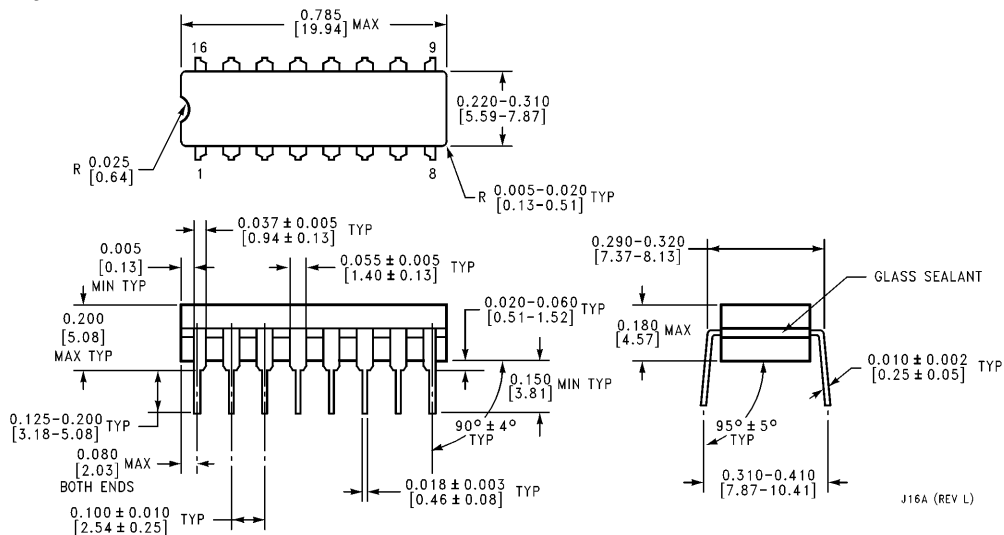

Ceramic Dual-In-Line Package (J)
Order Number CD4503BMJ or CD4503BCJ
NS Package Number J16A

Physical Dimensions inches (millimeters) (Continued)

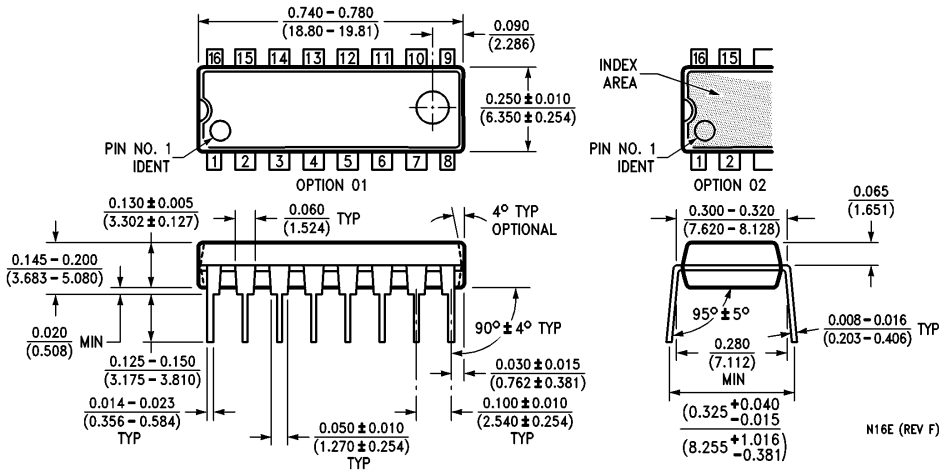

Moulded Dual-In-Line Package (N)
Order Number CD4503BMN or CD4503BCN
NS Package Number N16E

LIFE SUPPORT POLICY

NATIONAL'S PRODUCTS ARE NOT AUTHORIZED FOR USE AS CRITICAL COMPONENTS IN LIFE SUPPORT DEVICES OR SYSTEMS WITHOUT THE EXPRESS WRITTEN APPROVAL OF THE PRESIDENT OF NATIONAL SEMICONDUCTOR CORPORATION. As used herein:

1. Life support devices or systems are devices or systems which, (a) are intended for surgical implant into the body, or (b) support or sustain life, and whose failure to perform, when properly used in accordance with instructions for use provided in the labeling, can be reasonably expected to result in a significant injury to the user.
2. A critical component is any component of a life support device or system whose failure to perform can be reasonably expected to cause the failure of the life support device or system, or to affect its safety or effectiveness.



National Semiconductor Corporation
 1111 West Bardin Road
 Arlington, TX 76017
 Tel: 1(800) 272-9959
 Fax: 1(800) 737-7018

National Semiconductor Europe
 Fax: (+49) 0-180-530 85 86
 Email: cnjwge@tevm2.nsc.com
 Deutsch Tel: (+49) 0-180-530 85 85
 English Tel: (+49) 0-180-532 78 32
 Français Tel: (+49) 0-180-532 93 58
 Italiano Tel: (+49) 0-180-534 16 80

National Semiconductor Hong Kong Ltd.
 19th Floor, Straight Block,
 Ocean Centre, 5 Canton Rd.
 Tsimshatsui, Kowloon
 Hong Kong
 Tel: (852) 2737-1600
 Fax: (852) 2736-9960

National Semiconductor Japan Ltd.
 Tel: 81-043-299-2309
 Fax: 81-043-299-2408

National does not assume any responsibility for use of any circuitry described, no circuit patent licenses are implied and National reserves the right at any time without notice to change said circuitry and specifications.